



---

# BREWED COFFEE

## Branding Requirements and Setup Guidelines

---

**FOODSERVICE**





Thank you for choosing Starbucks and taking the time to ensure you're optimizing the customer experience. We have developed these easy to follow branding requirements and setup guidelines to give you the tools to deliver confidently and consistently on the promise of the Starbucks brand. Take some time to review these requirements to ensure you're delivering the experience customers expect while maximizing your sales.

Taken from our years of retail experience, the layout guidelines will provide a visual representation of optimal beverage setup, to help you run your operation as efficiently as possible. This includes recommendations for placement of supplies, fixtures/dispensers and ingredients to achieve the correct flow. The branding requirements will also provide visual representations of authorized and unauthorized use of branded materials, such as airpot rack signs, shuttle panels, posters and counter cards to ensure appropriate use of the We Proudly Serve Starbucks™ (WPS) logo and brand identity.

The branding requirements in this manual are intended to preserve the brand promise of Starbucks and the heritage entrusted to those who market the brand. Variations will exist from location to location based on the build of the operation, size and beverage offerings. Follow the station layout guideline and adjust as needed based on your space and design. **Branding requirements must be followed across all locations.**

## Table of Contents

- Setup Options to Fit Your Location..... 3
- Coffee Station Principles ..... 4
- Execution & Branding Requirements ..... 5
  - Branding Requirements for Your Location..... 6
  - Full Beverage Offerings..... 7-8
  - Shuttles & Back Panels.....9
  - Wall Signs.....10
  - Summary of Branded Materials.....11
  - Limited Space Options .....12-13
  - Airpot Rack Signs.....14
  - Point of Sale Marketing .....15
  - Custom Signage .....16
  - Summary of Branded Materials .....17
  - Out of Date Signage .....18
- Setup & Installation ..... 19
  - Back Panel Setup .....20
  - Wrap Application .....21-23
  - Decal Application .....24
- SKU Glossary .....25-28





Customers are led by attractive, eye-catching displays. Starbucks® branded signage can help you create the right impression and showcase the premium beverages you offer.

Below are merchandising setups that are optimized for brand presentation. Your location may vary based on available space.

## Area with at least 6 feet of space

### Works well for

Full Beverage Offering

All Equipment (supports shuttles and airpots)

### Branding Elements

Back panels, wraps, decals, paper products, point-of-sale signage, wall sign



## Area with limited space

### Works well for

Hot Beverage Offering

Airpots (3 or 6)

### Branding Elements

Airpot rack sign, wraps, decals, paper products



The setup examples illustrated in this guide are designed to facilitate the flow of traffic, helping your customers conserve time that's better spent connecting over a beverage than waiting in line.

## We followed these principles:

The order of items should follow the natural progression of coffee preparation, from cup to coffee to condiments. Regardless of your customer flow, customers should always encounter cups first and napkins last.

The items most easily forgotten or in need of replenishment (e.g., stir sticks, napkins, etc.) should be placed at the end of the setup, for quick retrieval without need to intersect the flow of traffic.

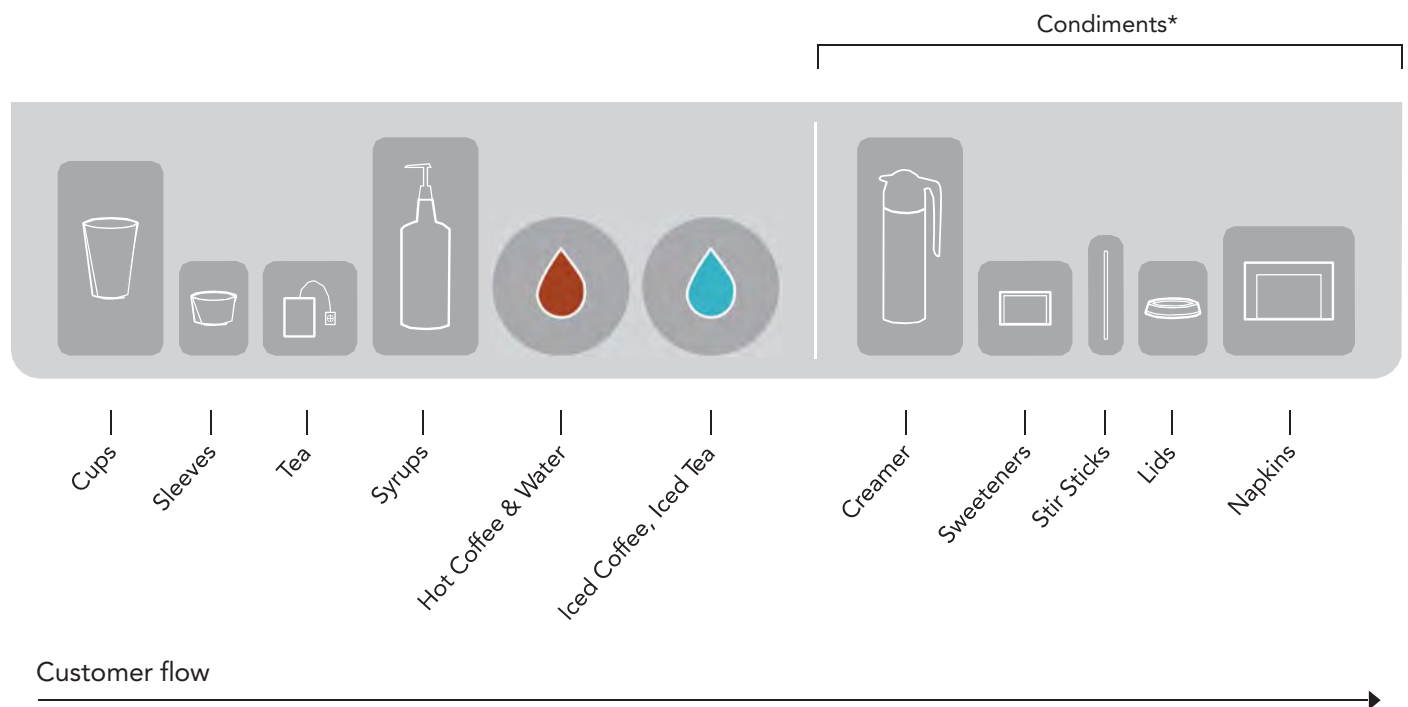

\* In some cases, general condiments (creamer, sweeteners, stir sticks) can be housed in a separate location vs. in-line with the coffee setup.





## **EXECUTIONS & BRANDING REQUIREMENTS**

The following pages will feature Coffee Station Setup principles and how to use our branded elements based on available space.



In order to promote your relationship with Starbucks, while setting appropriate customer expectations, please ensure you're following We Proudly Serve Starbucks™ logo requirements when setting up your location. Correct sizing of the We Proudly Serve Starbucks™ logo to your location logo ratio along with placement in your operation is key. Current requirements are available at <https://nestlecoffeepartnerssl.com> to ensure customers approaching your venue understand that it serves Starbucks® coffee, but is not a Starbucks® retail location. This may help to avoid confusion over promotional offerings or payment features that are specific to Starbucks® retail stores, and ultimately contribute to a better experience for your customers.

In this section you'll find requirements for branding your location with illustrations and photos of authorized and unauthorized placements, how and where to use a WPS Starbucks™ branded sign, plus seasonal and core point-of-sale marketing.







# FULL BEVERAGE OFFERING - COFFEE DISPENSER OPTIONS 7

The following executions (page 7 & 8) highlight full hot and iced beverage setups using 3 & 1.5 gallon shuttles and iced beverage dispensers. For locations with limited space, refer to the airpot hot coffee dispenser options on page 12 & 13.



Logo Wall Sign

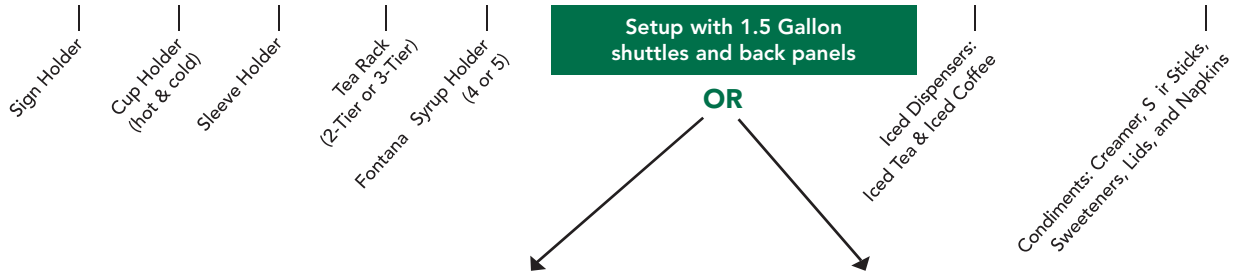

Setup with 3 Gallon shuttles and back panels

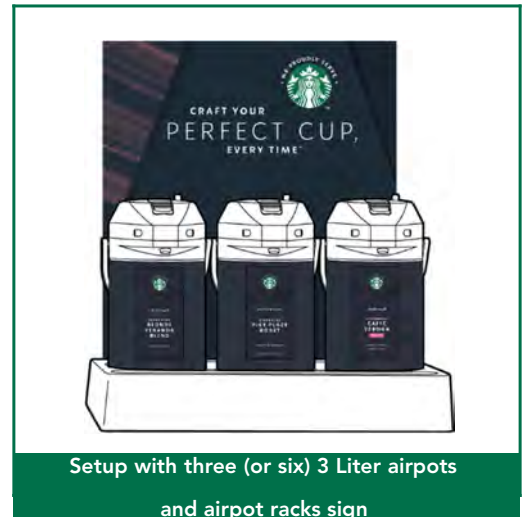

Setup with three (or six) 3 Liter airpots and airpot racks sign

Note: Item SKUs and descriptions available on page 11.



Logo  
Wall Sign



Setup with 3.5 Gallon shuttles

OR



Note: Item SKUs and descriptions available on the page 11.



### Shuttles & Back Panels

We have developed signage to help your customers identify that you serve Starbucks® brewed coffee. The back panels are designed for use with our shuttles only. For airpot options, see page 14.



### Don't

Mount to walls, suspend from ceiling, or alter in any other way

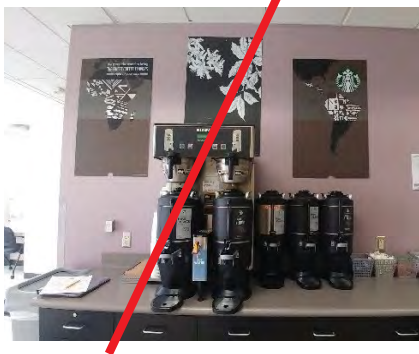

Display without shuttles.

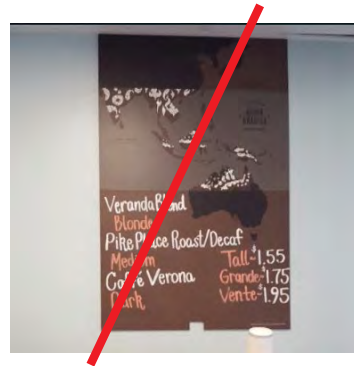

### Back Panels

Image	SKU	Description
	12438612	WPS Starbucks™ Back Panels (70.5" w x 36" h)



## Wall Signs

To promote that your location serves Starbucks® coffee, please use up to one We Proudly Serve Starbucks™ wall sign. WPS Starbucks™ wall signs can only be mounted to the wall, and are not permitted for use on the front of counter displays.

Display the sign on a back wall above the coffee station to catch the customer's eye from a distance.



### Don't

Place on front paneling or in front of a counter or on a register.

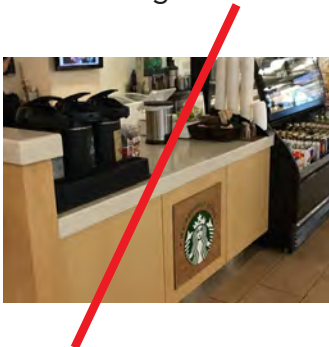

Stack WPS Starbucks™ logo directly above another WPS Starbucks™ logo.

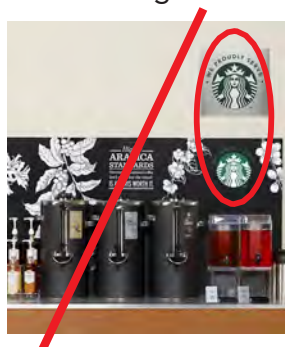

Place where operator identity is not visible.



Place on or facing the exterior of the location.



Image	SKU	Description
	12421298	WPS Starbucks™ Wall Sign (17"W x 16"H)



# SUMMARY OF BRANDED MATERIALS

The below chart provides a high level summary of the various marketing materials and appropriate usage. For more detailed information on each tool, please reference the appropriate corresponding section.

SKU	Description	SKU	Description
 12438612	WPS Starbucks™ Back Panels (double-sided with different graphics)	 12420812	Panel Stands (4 per case)
 12421298	WPS Starbucks™ Logo Wall Sign (17" w x 16" h)	 12420989 12420990 12421310	2-Tier Tea Rack 3-Tier Tea Rack 3 Tier Narrow Tea Rack
 12438713 12438719 12438589	Veranda Blend® Decal Pike Place® Roast Decal Caffè Verona® Decal  A complete list of decals can be found on page 26	 12420740	4 section cup holder— 8, 12, 16, 20 oz. hot cups and lids
 12438617	WPS Starbucks™ 3 Gallon Bunn® Titan™ Shuttle Wrap	 12420739	3 section cup holder— 12, 16, 24 oz. cold cups and lids
 12421154	WPS Starbucks™ 3.5 Gallon Iced Coffee Wrap (narrow)	 12420838	4x4 Plexi Cube— For splash sticks and condiments
 12421239	3 gallon acrylic dispenser	 12413946 12420671	4-Hole Plexi Syrup Rack 5-Hole Plexi Syrup Rack
 12421240	1.5 gallon acrylic dispenser	 12420741 12420742	Vertical Sleeve Holder – 12" Horizontal Sleeve Holder – 18"
 12421265	WPS Starbucks™ ID Stand: Cold Brew	 12420661	8.5" x 11" Sign Holder
 12421375 12421376 12421378 12421377	<b>Teavana® :</b> Iced Black Tea ID stand Iced Green Tea ID stand Iced Passion Tango ID stand Iced White Tea ID stand	 12420788	1 Liter Carafe
 12421379	Teavana® 3.5 Gallon Narrow Iced Tea wrap	 12421371 12421372 12421374 12421373	<b>Teavana® :</b> Iced Black Tea decal Iced Green Tea decal Iced Passion Tango decal Iced White Tea decal



SKU	Description	SKU	Description
	12438710 WPS Starbucks™ Airpot Rack Sign		12420739 3 section cup & lid holder 12, 16, 24 oz. cold cups and lids
	12420700 Airpot Rack 3 12421505 Airpot Rack 6		12420740 4 section cup & lid holder 8, 12, 16, 20 oz. hot cups and lids
	12438614 WPS Starbucks™ 3 Liter Airpot Wrap		12420838 4x4 Plexi Cube— For splash sticks and condiments
	12438713 Veranda Blend® Decal 12438719 Pike Place® Roast Decal 12438589 Caffè Verona® Decal A complete list of decals can be found on page 26		12420741 12" Vertical Sleeve Holder 12420742 18" Horizontal Sleeve Holder
	12420989 2 Tier Tea Rack 12421310 3 Tier Narrow Tea Rack		12420788 1 Liter Carafe



# LIMITED SPACE AND HEIGHT - AIRPOT HOT BEVERAGE OPTIONS 13

## Setup with three 3 Liter airpots













Cup Holder  
Sleeve Holder



## Setup with six 3 Liter airpots

Condiments: Creamer, Stir Sticks  
Sweeteners, Lids, and Napkins

SKU	Description	SKU	Description
	12441495 WPS Starbucks™ Airpot Rack Logo Decal		12420739 3 section cup & lid holder 12, 16, 24 oz. cold cups and lids
	12420700 Airpot Rack 3		12420740 4 section cup & lid holder 8, 12, 16, 20 oz. hot cups and lids
	12438614 WPS Starbucks™ 3 Liter Airpot Wrap		12420838 4x4 Plexi Cube— For splash sticks and condiments
	12438713 Veranda Blend® Decal 12438719 Pike Place® Roast Decal 12438589 Caffè Verona® Decal A complete list of decals can be found on page 26		12420742 18" - Horizontal Sleeve Holder
	12420989 2Tier Tea Rack 12421310 3Tier Narrow Tea Rack		12420788 1 Liter Carafe



### Airpots & Airpot Rack Signs

We have developed signage to help your customers identify that you serve Starbucks® brewed coffee. The airpot rack sign is specifically designed for use with the three or six hole airpot rack fixture. When space does not permit use of the airpot rack sign, use the airpot rack decal.



#### To set up airpot rack signs:

1. Both the 3 and 6 airpot racks have groves in the back to allow for easy installation of the airpot rack sign.
2. Position the two flaps at the bottom of the airpot rack sign into the two groves in the airpot rack.
3. Push down gently until the groves are no longer visible and the airpot rack sign rests on top of the airpot rack.

#### Don't

Use back panels with an airpot setup.



Affix signs to the wall.

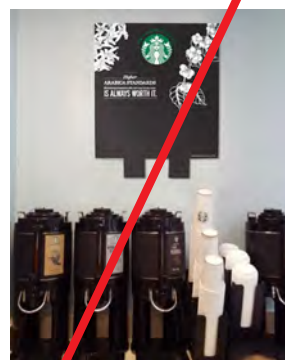

### Airpot Rack Sign

Image	SKU	Description
	12438710	WPS Starbucks™ Airpot Rack Sign (22" w x 27.5" h)





## Core and Seasonal Marketing Point-of-Sale

Ensure you're set up to receive our seasonal marketing automatically to help drive business year round and generate awareness for the latest limited time offerings. Maximum 1 counter card and 1 poster frame per location total.



### Counter Cards

Place in customer view/sight prior to ordering.  
Ensure current promotion is always on display.  
Ensure counter cards are in frames.

### Posters

Always mount posters to walls using frames.

### Don't

Line up multiples side by side.  
Exceed one 8.5. x 11 counter card frame.  
Display out of date marketing POS or counter cards.

Exceed 1 poster mounted to walls.  
Hang in exterior windows.  
Hang outdated marketing.  
Use chipped or cracked frames – these should be replaced.

## Marketing POS Sign Holders

Image	SKU	Description
	12420661	8.5" x 11" Sign Holder/Chalkboard
	12420660	5" x 7" Sign Holder/Chalkboard
	12421314	22" x 26" Poster Frame



## Custom Materials

Custom materials created by the operator must include the operator's name or logo as the primary means of identification, with the WPS Starbucks™ logo or wordmark no larger than a 1/4 the size of the operator logo. The WPS Starbucks™ logo or wordmark may never be used independent of the operator logo on custom pieces, used without the We Proudly Serve text or altered in any way.

The priority of the branding should always be the locale's name and execution rather than Starbucks. This helps ensure you're setting the right expectation and experience for customers visiting your operation. At no time, should the Starbucks provided branded marketing materials be altered outside required execution - i.e. do not cut to fit area/shapes. Prior to creating custom materials, please consult our Logo Requirements. Logos and other assets are available by request from [mbFSMarketing@us.nestle.com](mailto:mbFSMarketing@us.nestle.com).

***ALL MENU BOARDS MUST BE APPROVED PRIOR TO EXECUTION.***

To request approval, please fill out the FSMarketing Review and Approval Form at [www.nestlecoffeepartnersSL.com/fsmarketing](http://www.nestlecoffeepartnersSL.com/fsmarketing)

If final designs have not been submitted for review or are used without our approval, the operator will be responsible for removing unauthorized materials or correcting any mistakes at their own cost.

Please reach out to [mbFSMarketing@us.nestle.com](mailto:mbFSMarketing@us.nestle.com) for asset requests or questions.

### Don't

Incorporate the We Proudly Serve Starbucks™ Logo into your location's signage without also including your operation's own logo.

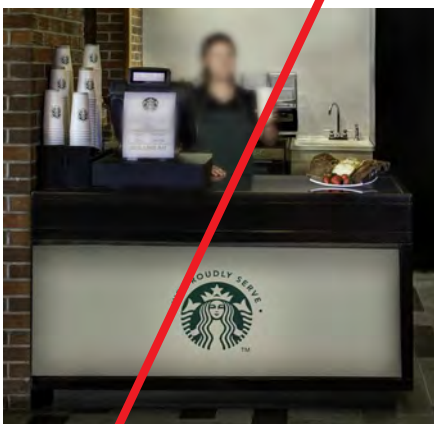

Alter Starbucks provided branded marketing outside required execution, i.e. do not cut to fit area or shapes.

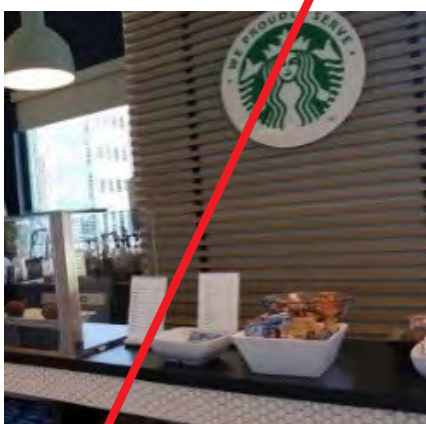







Use old We Proudly Brew branding or use Starbucks® retail signage or logo.





The below chart provides a high level summary of the various marketing materials and appropriate usage. For more detailed information on each tool, please reference the appropriate corresponding section.

Tool	Maximum Use	Notes	
	<p><b>Wall Sign</b></p>	<p>1</p>	<p>Must be mounted to wall above brewed coffee setup</p>
	<p><b>Blade Signs</b> (12x12 or vertical)</p>	<p>1 from each direction</p>	<p>May only be used when venue is not immediately visible</p>
	<p><b>Posters</b></p>	<p>1</p>	<p>Must be current and mounted to wall above coffee setup</p>
	<p><b>Counter Card</b></p>	<p>1</p>	<p>Must be current</p>
	<p><b>Airpot Rack Sign</b></p>	<p>1</p>	<p>Must only be used with airpot rack; cannot be affixed to wall</p>
	<p><b>Back Panels</b></p>	<p>1 set of 3 panels</p>	<p>Any combination of 1,2 or all three back panels; cannot be affixed to wall or suspended from ceiling</p>
	<p><b>Custom Marketing</b></p>	<p>-</p>	<p>Must follow logo requirements and be approved through FSMarketing</p>



## Dos & Don'ts with Inline Expression signage

Our Inline Expression (navy and wood) marketing is the current branding for We Proudly Serve Starbucks™ locations. This branding should be used for account refreshes and new openings. The Chalk Coffee Cherry/Coffee Belt branding is acceptable so long as it is not mixed with the new marketing.

### OK

The chalk coffee cherry/coffee belt signage is still acceptable to use in existing locations.



### Don't

The coffee cherry chalk/coffee belt signage CANNOT be mixed and matched with inline expression signage.



### Don't

Any signage with the We Proudly Brew logo or other old design is out of date and must be replaced with current We Proudly Serve Starbucks™ marketing. The images below will help you identify signage that is out of date.

#### Old Logo



#### Old Decals



#### Old Branded Signage



#### Old Back Panels



#### Old Wraps



## **SETUP & INSTALLATION**

The following pages will help guide you through the process for installing back panels, applying wraps and decals and help ensure your setup provides the optimal brand experience.



### Inserting clips onto panels:



### Inserting panels into stands:



Depending on your space you will want to use a one-panel, two-panel or three-panel execution.



One Panel



Two Panels



Three Panels

*Note: Setting up with two people will yield best results*

### To set up back panels:

1. Hold the "H" clip firmly in one hand and Back Panel A in the other hand.

2. With consistent pressure, press Clip onto the right edge of Panel A approx. 6" from top of the panel.

3. Attach second clip on same edge of Panel A, approx. 12" from the bottom.

4. Insert Panel A into the base panel stands — one stand aligned with far left edge of Panel A and the right edge of Panel A halfway into the second stand.

**Note:** The second stand will be shared with Panel B.

5. Align Panel B next to the clips on Panel A and press together, making sure that the top and bottom of the two panels are aligned, as you also slide the left edge of the panel into the second panel stand. Insert the bottom-right edge of Panel B halfway into the third panel stand (will share with Panel C).

6. Attach clips on right edge of Panel B, repeating steps 2 and 3 above.

7. Align Panel C next to the clips on Panel B and press together, inserting the bottom of Panel C into the third and fourth panel stands. The fourth stand should align with the bottom-right edge of Panel C.

8. Once all three Panels are attached and in the panel stands, do a final check for alignment.

### Tips for removing the clips

Removing requires a firm hold/pull. Bend the panels at the clip-hinges back and forth to loosen. Then, wiggle the panel (or the clip) and firmly pull the clip off the panel.

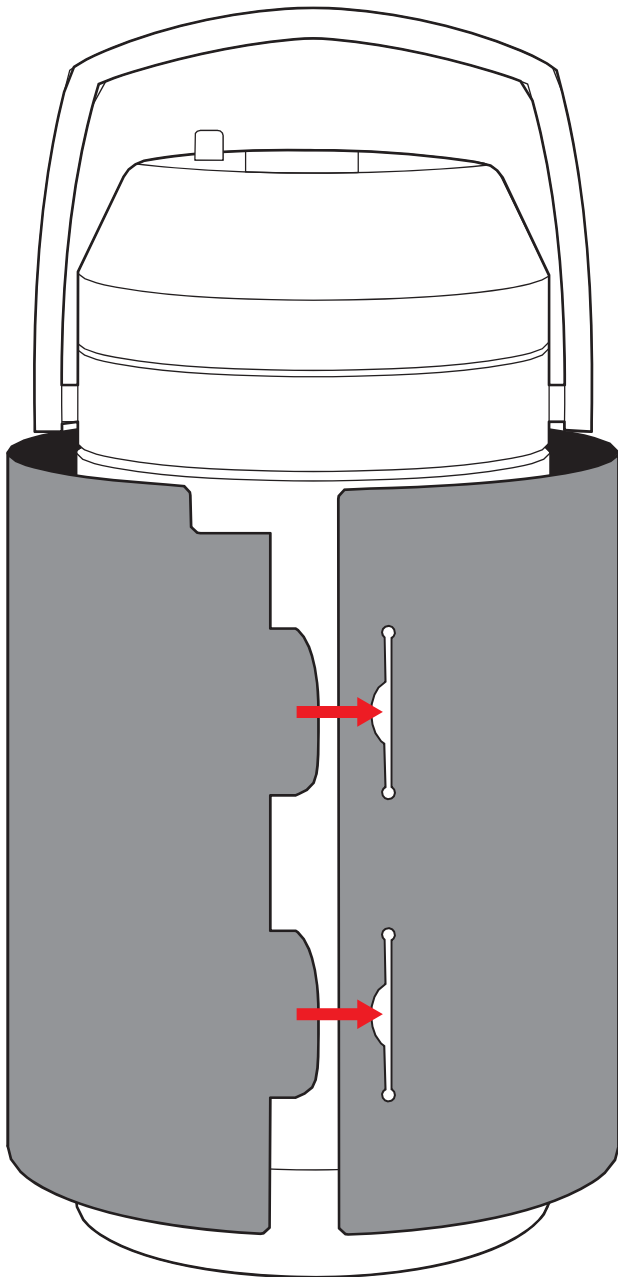

**Before adhering a new wrap, remove any existing wrap.**

**To remove an existing wrap:**

1. Release the tabs in the back of the dispenser and disconnect the interlocking fasteners.
2. One of the 1" square interlocking fasteners should remain adhered to the airpot. Use it as a guide when re-applying.

**To clean the airpot wrap:**

1. Wipe airpot wrap down with a clean, damp cloth and mild soap.
2. DO NOT USE abrasive materials or cleaning agents on airpot wrap or interlocking fasteners.

**To apply a new wrap:**

1. Peel liner off the 1" square interlocking fastener. Do not separate the two pre-joined squares.
2. Align the airpot wrap so that the front is centered.
3. Adhere the 1" interlocking fastener to the back of the airpot. The fastener should align with the bottom of the hinge.
4. Lightly "tack" together all interlocking fasteners (1" squares and strips) and check for accurate alignment.
5. Firmly press all interlocking fasteners together and tuck tabs into slits.



Note: Works for 3 Gallon Fetco® & Bunn® shuttles

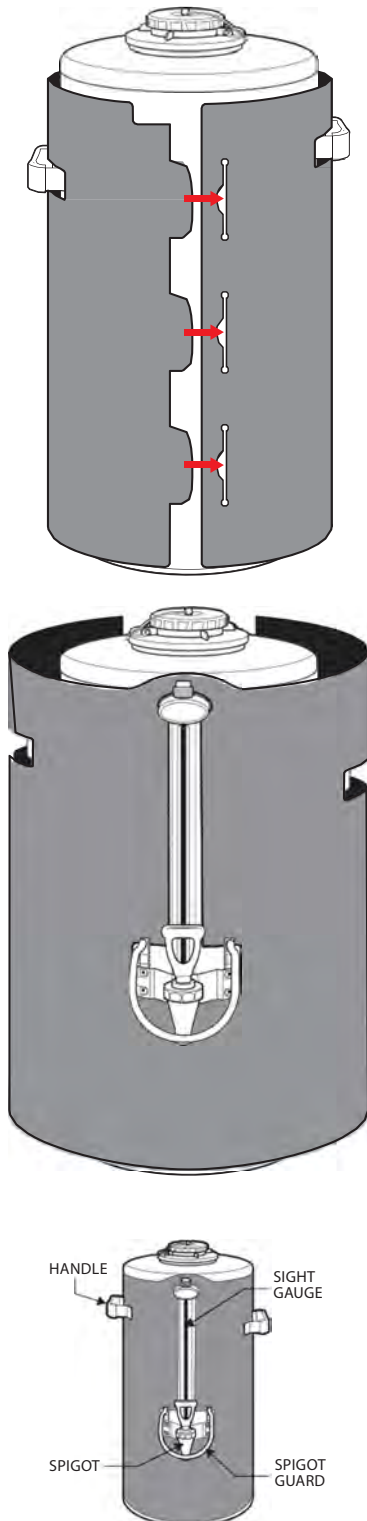

**Before adhering a new wrap, remove any existing wrap.**

**To remove an existing wrap:**

1. Release the tabs in the back of the dispenser and disconnect the interlocking fastener.
2. One side at a time, remove from handle and carefully peel off the gel strip next to the sight gauge. Start at the bottom and gently work upward. Repeat this process on the other side.
3. With both handles and gel free, first pull the bottom of the shuttle wrap out from the spigot, then lift over the top of the sight gauge.

**To clean the wrap:**

1. Wipe the shuttle wrap down with a damp cloth and mild soap. DO NOT wipe the gel strips.
2. If gel appears to be losing its grip, rinse it with cool water and let air dry. DO NOT wipe gel with rag or paper towel. Fibers from these materials will stick to the gel and force you to clean it again.

**To apply a new wrap:**

1. IMPORTANT! Clean the server. Surface must be free of grease, polish, grime, dirt, coffee, etc., or the gel will not adhere properly.
2. Place shuttle wrap over the top of the sight gauge and then around the spigot guard. Rest the handle cut-outs over the handles. Careful, don't kink the shuttle wrap!
3. From both sides of the spigot guard, fit the shuttle wrap snugly around the dispenser and "tack" it down by pushing on a section of the interlocking fastener.
4. Make sure the shuttle wrap is centered and snug. The tabs should line up evenly with slits in the back of the dispenser.
5. Press together the remaining interlocking fastener along the "spine" of the dispenser. Tuck in tabs.
6. In front of the dispenser, remove the liners of the two gel strips located next to the sight gauge. Pull up, not out, and then press firmly to adhere the gel strips to the body of the dispenser.





## 1.5 GALLON SHUTTLE WRAPS - APPLICATION & REMOVAL 23

Note: Works for 1.5 Gallon Bunn® shuttles

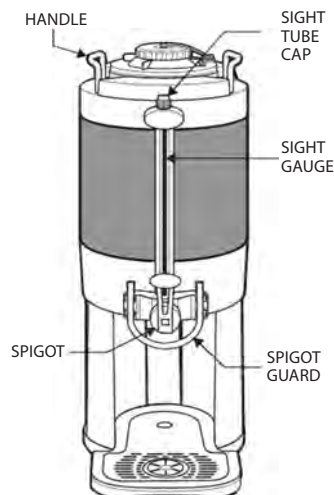
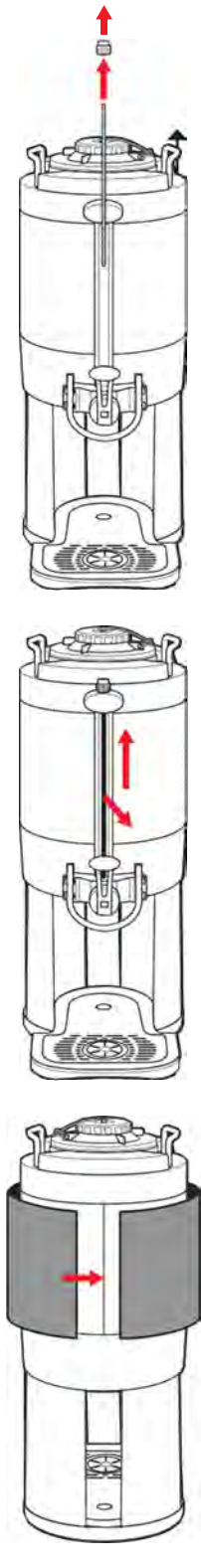

**Before adhering a new wrap, remove any existing wrap.**

### To remove an existing wrap:

1. Release the tabs in the back of the dispenser and disconnect the interlocking fastener.
2. One side at a time, remove from handle and carefully peel off the gel strip next to the sight gauge. Start at the bottom and gently work upward. Repeat this process on the other side.
3. With both handles and gel free, first pull the bottom of the shuttle wrap out from the spigot, then lift over the top of the sight gauge.

### To clean the wrap:

1. Wipe the shuttle wrap down with a damp cloth and mild soap. DO NOT wipe the gel strips.
2. If gel appears to be losing its grip, rinse it with cool water and let air dry. DO NOT wipe gel with rag or paper towel. Fibers from these materials will stick to the gel and require you to clean it again.

### To apply a new wrap:

1. Unscrew the sight tube cap and set aside.
2. Remove the sight tube from the sheath.
3. Remove the sight tube sheath by gently pulling the base of the sheath out and pushing up. (Do not touch or move the newly exposed screw.)
4. Gently peel the sticker strip on the right side of the wrap (which has the SKU number on it). Align the wrap with the shuttle's back seam, and push down from right to left to tack the wrap down. Repeat for the left side.
5. Once the wrap has been applied, align the divot in the back of the sight tube sheath to the exposed screw on the shuttle and gently push down until affixed.
6. Re-insert the sight tube into the sheath and screw on the sight tube cap.

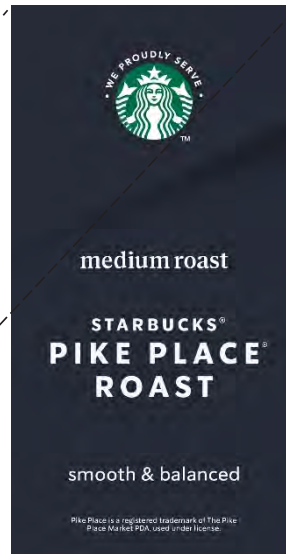
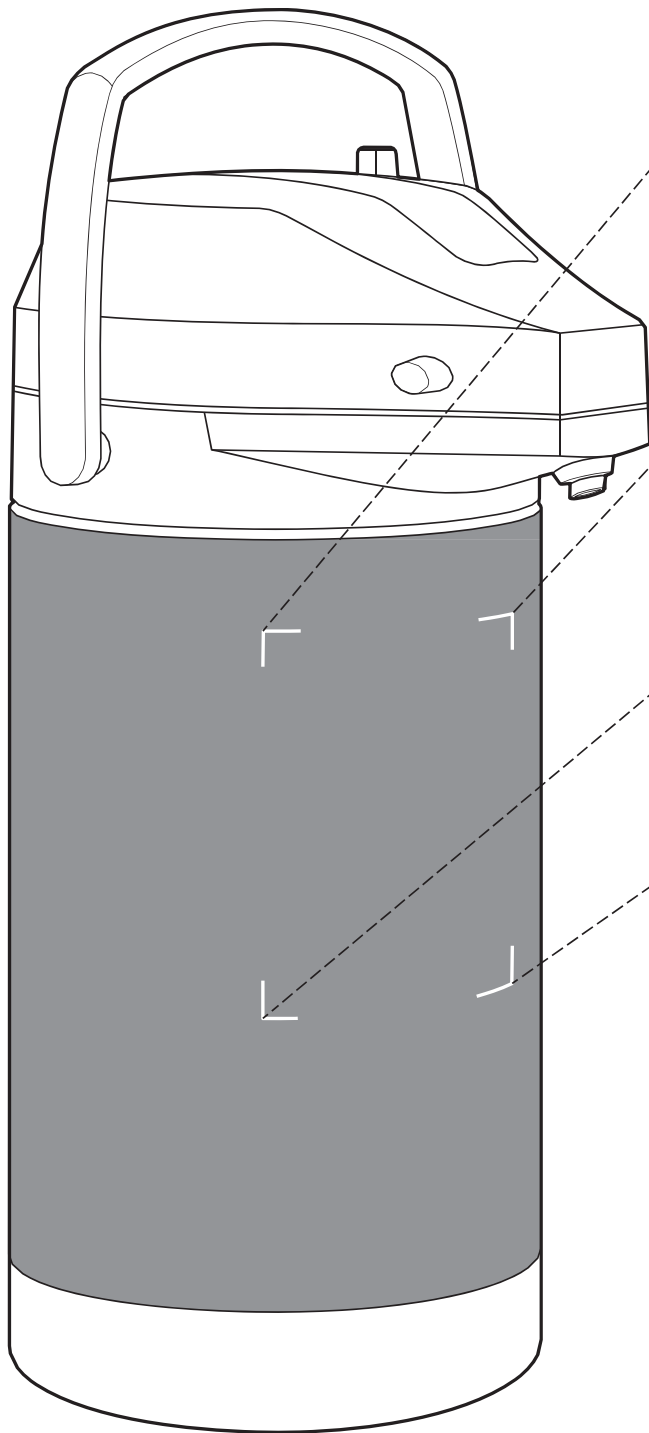

**Before adhering a new decal, remove any existing decal. A decal should be replaced when it is torn or peeling. If you are unable to cleanly remove the decal from the wrap, order a replacement wrap. Do not put a new decal over an existing decal.**

**To remove an existing decal:**













1. Carefully peel the existing decal from the airpot or shuttle.
2. Discard the decal.

**To apply a new decal:**













1. Peel the decal from its backer paper.
2. Align decal with the corner guide marks on the wrap and apply so that the corners of the decal cover the marks.
3. Ensure the decal is straight, then smooth it carefully over the surface of the wrap.

## **SKU GLOSSARY**











Item Name/SKU	Description	
<b>Signage</b>		
	WPS Starbucks™ Back Panels – 12438612	<b>Dimensions:</b> Each panel: 23.5" w x 36" h 3-panel set: 70.5" w x 36" h (Back Panels are double-sided with different graphics)
	Panel Stands – 12420812	For use with the Back Panels. Includes four per case.
	WPS Starbucks™ Logo Wall Sign – 12421298	17" w x 16" h with mounting bracket
	WPS Starbucks™ Airpot Rack Sign – 12438710	22" w x 27.5" h, incl. 3.5" h cutouts.
	Airpot decal – 12441495	Decal for use on front of Airpot Racks. Approx. 22" w x 3.5" h with adhesive backing.
	WPS Starbucks™ Vertical Blade Sign – 12420959	6.5" w x 33.5" h
	WPS Starbucks™ Small Blade Sign – 12420957	12" w x 12" h
<b>Decals, Identifiers and Wraps</b>		
	<b>Hot Beverage Decals</b> Breakfast Blend – 12438619 Café Estima Blend® – 12438588 Caffè Verona® – 12438589 Pike Place® Roast – 12438719 Serena Organic Blend™ – 12438721 Veranda Blend® – 12438713 French Roast – 12438630 Decaf Breakfast Blend – 12438633 Decaf Fair Trade Blend – 12441346 Decaf Caffè Verona® – 12438632 Decaf Pike Place® Roast - 12438720 Decaf Serena Organic Blend™ - 12438634 Decaf Veranda Blend® – 12438714 Kopelani Blend® (Hawaii Only) – 12441347 Hot Water – 12438711	For use on airpots and shuttles; apply to the front of the airpot or shuttle wrap.  3" w x 6" h with adhesive backing.
	WPS Starbucks™ 3 Liter Airpot Wrap – 12438614	<b>ALL WRAPS</b> WPS Starbucks™ wraps visually showcase the premium feel of the Starbucks brand as well as the long heritage of the company.  Order WPS Starbucks™ coffee or hot water decal(s) to apply to the front of the wrap.
	WPS Starbucks™ 1.5 Gallon Bunn® Shuttle Wrap – 12438615	
	WPS Starbucks™ 1.5 Gallon Luxus® Shuttle Wrap – 12438604	
	WPS Starbucks™ 3 Gallon Bunn® Titan™ Shuttle Wrap 12438617	
	WPS Starbucks™ 3 Gallon Luxus® Shuttle Wrap – 12438618	



Item Name/SKU	Description
<b>Decals and Wraps (cont.)</b>	
	<b>Starbucks® Banquet ID Stands</b> <b>Coffee – 12420960</b> <b>Decaf – 12420961</b> <b>Hot Water 12420962</b> <b>Cold Brew - 12421265</b>  Face of sign is 3" w x 4" h.
	WPS Starbucks™ 3.5 Gallon Iced Coffee Wrap (narrow) – 12421154  For use on the narrow Bunn® 3.5 Gallon iced beverage dispenser. No decal is necessary.
	WPS Starbucks™ 3 Gallon Iced Coffee Wrap (round) – 11021194  For use on the Bunn® 3 Gallon iced beverage dispenser. No decal is necessary.
<b>Fixtures</b>	
	Airpot Rack 3 – 12420700 Airpot Rack 6 – 12421505  Approx. 22.5" w x 3.5" h x 12" d Approx. 22.5" w x 12.5" h x 24" d
	Napkin Dispenser – 12421041  Non-branded black napkin dispenser. 8" w x 6" h x 11.75" d
	4-Hole Plexi Syrup Rack – 12434003 5-Hole Plexi Syrup Rack – 12420671  Made of Plexiglas.
	Sign Holder – 5" w x 7" h – 12420660 Sign Holder – 8.5" w x 11" h – 12420661  May be used with counter cards or sign inserts.
	Poster Frame -22" x 26" – 12421314  Black wooden poster frame fits posters size 22" x 26", clear style hanger.
	Vertical Sleeve Holder – 12420741 Horizontal Sleeve Holder – 12420742  Vertical sleeve holder is 12" tall and horizontal sleeve holder is 18" deep.
	4x4 Plexi Cube - 12420838  For splash sticks and condiments
	3 gallon acrylic dispenser – 12421239  For Iced Coffee & Iced Tea
	1.5 gallon acrylic dispenser – 12421240  For Iced Coffee & Iced Tea



Item Name/SKU	Description
Fixtures (cont.)	
	4-slot holder – 12420740 4 hole cup, lid and straw holder. Holds all size hot and cold cups and lids.
	3 section cup holder – 12420739 3 section cup holder for 12, 16, 24 oz. cold cups and lids
	1 Liter Carafe – 12420788 Use for milk or cream.
	Carafe Band Half & Half - 12432316 Carafe Band 2% - 12432317 Carafe Band Non-Fat - 12432318 Carafe Band Soy - 12432319 Carafe Band- Whole Milk - 12432320 Identifiers for dairy carafes. Pack of 3.
Tea	
	<b>Tea Racks</b> 2 Tier – 12420989 3 Tier – 12420990 3-Tier Narrow – 12421310 2 tier holds 8 boxes of Tea. 11" w x 12" h x 3" d 3 tier holds 12 boxes. 11" w x 17" h x 3" d 3-tier narrow holds 6 boxes. 7" w x 5.5" d x 17.5" h
	<b>Teavana® :</b> Iced Black Tea ID stand - 12421375 Iced Green Tea ID stand - 12421376 Iced Passion Tango ID stand - 12421378 Iced White Tea ID stand - 12421377 Face of sign is 3" w x 4" h.
	<b>Teavana® :</b> Iced Black Tea decal - 12421371 Iced Green Tea decal - 12421372 Iced Passion Tango decal - 12421374 Iced White Tea decal - 12421373 3.125" w x 6" h For use on wrapped or plastic iced tea dispensers.
	Teavana® 3.5 Gallon Narrow Iced Tea wrap - 12421379 For use on the Bunn® 3.5 gallon iced dispenser. Iced tea decal sold separately.



For more information, contact your Nestlé  
Coffee Partners representative or visit  
<https://www.nestlecoffeepartnerssl.com>.  
For more information on custom marketing,  
contact [mbFSMarketing@us.nestle.com](mailto:mbFSMarketing@us.nestle.com)

Confidential. For Nestlé Coffee Partners business purposes only.

STARBUCKS and the Starbucks logo are used under license by Nestlé.  
Pike Place is a registered trademark of The Pike Place Market PDA, used under license.

SFS-007-WPS-BCH-1291